

NOTES:

SPECIFICATION:

1. CURRENT RATING: 3.0 A
2. VOLTAGE RATING: 30 V
3. VBUS & GND PINS AND OTHER PINS: 40mΩ/PIN MAX
SHIELD: 50mΩ/MAX
LLCR MAX. CHANGE OF ALL PINS: 10Ωm
4. INSULATION RESISTANCE: 100MΩ MIN
5. DIELECTRIC WITHSTAND VOLTAGE, AC 100V FOR 1MINUTE
6. INSERTION FORCE: 0.5~2.0kgf
7. UNMATING FORCE: 0.8-2.0kgf
8. DURABILITY: 10000 CYCLES
9. OPERATING TEMPERATURE: -35°C~+85°C
10. THE PEAK TEMPERATURE ON THE BOARD SHALL BE MAINTAINED FOR 10 SECONDS AT 2 10-250°C
11. WATERPROOF: IP-X7.

USB TYPE C PIN ASSIGNMENTS

PIN NUMBER	SIGNAL NAME	PIN NUMBER	SIGNAL NAME
A1	GND	B12	GND
A4	VBUS	B9	VBUS
A5	CC1	B8	SBU2
A6	DP1	B7	DN2
A7	DN1	B6	DP2
A8	SBU1	B5	CC2
A9	VBUS	B4	VBUS
A12	GND	B1	GND

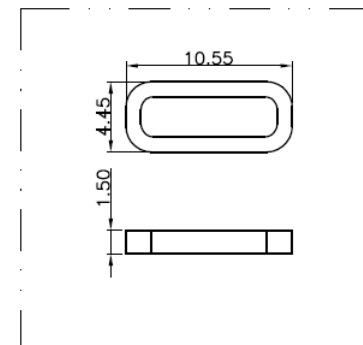
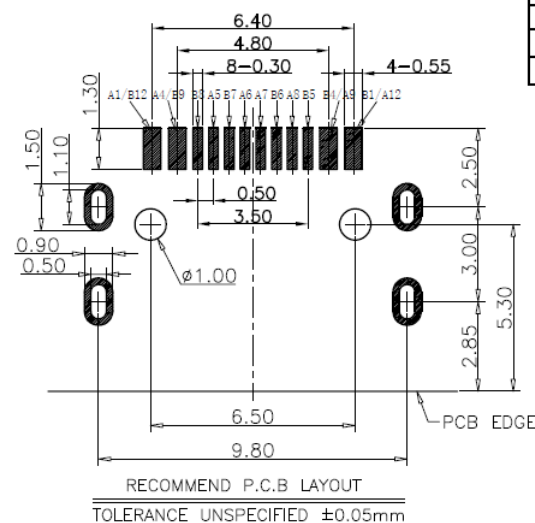

8										
7										
6										
5										
4										
3	SHELL	STAINLESS STEEL	1	Sn PLATED	TITLE: USB JACK	UNIT:mm	DRWG. NO.:			
2	TERMINAL	BRONZE	16	Au PLATED	MODEL NO: EIO1203	SCALE:4:1	DWN			
1	HOUSING	LCP	1	BLACK	Summit Electronics bv				CHK'D	
NO.	DESCRIPTION	MATERIAL	QTY	PLATING					APPD.	